

S SERIES

STEAM BOILERS



- Digital Modulation Family responds to your varying process and operational demands for steam and hot water.
- An industry-leading breakthrough in rapid-response, variable output, compactness and low maintenance!
- Easier interface with process control/automation via common communications protocols.
- Patents Pending design innovation from the leader in firetube boilers that eliminate thermal shock.

STEAM BOILER RATINGS, CAPACITIES, WEIGHTS

BOILER HORSE POWER	HOURLY GAS INPUT (1,000BTU)	GROSS HOURLY OUTPUT (1,000BTU)	TURN-DOWN	FUEL OPTIONS	POUNDS OF STEAM PER HOUR (1)	LOW NO _x EMISSIONS OPTION (2)	NORMAL WATER CAPACITY (U.S. GAL)	FLOODED WATER WEIGHT (LBS)	SHIPPING WEIGHT (POUNDS)	
									15 PSI	150 PSI
40	1,674	1,339	3 to 1	NG, LP	1,380	30 PPM	186	1,919	3,120	3,120
50	2,092	1,674	3 to 1	NG, LP	1,725	30 PPM	180	1,863	3,250	3,250
60	2,511	2,009	3 to 1	NG, LP	2,070	30 PPM	175	1,825	3,330	3,330
70	2,929	2,343	3 to 1	NG, LP	2,415	30 PPM	265	2,702	4,200	4,240
80	3,348	2,678	3 to 1	NG, LP	2,760	30 PPM	259	2,655	4,380	4,420
100	4,184	3,348	3 to 1	NG, LP	3,450	30 PPM	374	3,655	5,020	5,480
125	5,231	4,184	3 to 1	NG, LP	4,313	30 PPM	333	3,519	5,430	5,800
150	6,277	5,021	3 to 1	NG, LP	5,175	30 PPM	435	4,662	7,230	7,490
175	7,323	5,858	3 to 1	NG, LP	6,038	30 PPM	406	4,541	7,480	7,740
200	8,369	6,695	4 to 1	NG, LP	6,900	30 PPM	553	5,853	8,980	9,310
250	10,461	8,369	4 to 1	NG, LP	8,625	30 PPM	679	7,238	10,230	10,550
300	12,553	10,043	4 to 1	NG, LP	10,350	30 PPM	830	8,982	11,200	12,320
350	14,645	11,716	4 to 1	NG, LP	12,075	30 PPM	779	8,753	11,740	12,990
400	16,738	13,390	4 to 1	NG, LP	13,800	30 PPM	958	10,707	13,750	14,610
500	20,922	16,738	4 to 1	NG, LP	17,250	30 PPM	1,083	12,596	16,690	17,310
600	25,107	20,085	4 to 1	NG, LP	20,700	30 PPM	1,233	14,676	17,410	18,990
700	29,291	23,433	4 to 1	NG, LP	24,150	30 PPM	1,418	16,987	22,330	22,960
800	33,475	26,780	4 to 1	NG, LP	27,600	30 PPM	1,622	19,521	26,300	26,930
900	37,659	30,127	4 to 1	NG, LP	31,050	30 PPM	3,263	27,116	31,770	32,865

(1) From 212 degrees F. feed water to atmospheric pressure. (2) Low NO_x may effect Turndown.

GAS REQUIREMENTS

Main and pilot gas pressure regulators are supplied with each boiler. Refer to the chart below for gas pressure requirements. Pressures shown are with the unit running.

BOILER HORSEPOWER	PRESSURE REQUIRED AT GAS TRAIN INLET
	STD RANGE
40-80	1 to 5 PSI
100-150	1 to 5 PSI
175-200	1 to 5 PSI
250	1 to 5 PSI
300-350	2 to 10 PSI
400-900	2 to 10 PSI

For high and low gas pressure applications consult the factory.

ELECTRICAL REQUIREMENTS

A single incoming power connection is required to the junction box provided at the hinge of all boilers. Boilers are wired for jobsite supply power characteristics.

STACK REQUIREMENTS

Design stack to provide +/- 0.1" water column draft at flue outlet. Smooth transitions and bends are required. Maximum stack weight on boiler should be 1,000 pounds on 40 to 80 HP and 2000 pounds for 100 to 900 HP units.

AIR REQUIREMENTS

Provide 1/2 square foot of free air inlet area per 1,000,000 BTU input to the burner. Cross ventilation is preferred in lieu of a single opening.

Sellers Fits Where Others Won't

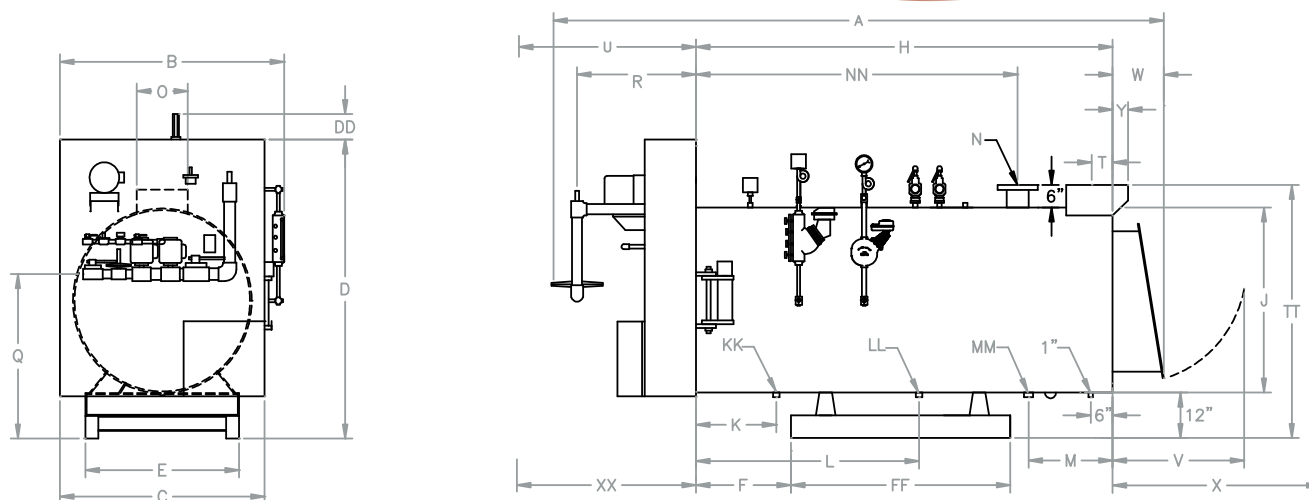

STEAM BOILER DIMENSIONS

HORSEPOWER		40	50	60	70	80	100	125
OVERALL DIMENSIONS:								
LENGTH	A	144	143	145	149	149	160	160
WIDTH	B	42	42	42	48	48	55	55
BURNER WIDTH	C	35	35	35	41	41	47	47
BURNER HEIGHT	D	65	65	65	70	70	75	75
SECONDARY AIR CAP HEIGHT	DD	6	6	6	6	6	6	6
BASE:								
WIDTH	E	24	24	24	30	30	36	36
LOCATION	F	20	20	20	20	20	26	26
LENGTH	FF	60	60	60	60	60	60	60
SHELL:								
LENGTH	H	108	108	108	108	108	114	114
DIAMETER INSIDE	J	30	30	30	36	36	42	42
SHELL CONNECTIONS:								
BLOWDOWN LOCATION	K	16	16	16	16	16	22	22
MANUAL FILL SIZE	LL	-	-	-	-	-	-	-
MANUAL FILL LOCATION	L	-	-	-	-	-	-	-
FEEDWATER INLET SIZE	MM	1	1	1	1.25	1.25	1.25	1.25
FEEDWATER INLET LOCATION	M	23	23	23	23	23	23	23
STEAM OUTLET LOCATION	NN	82	82	82	82	82	88	88
LOW PRESSURE (15 PSI) BOILERS:								
STEAM OUTLET SIZE (NOTE 3)	N	6f	6f	6f	8f	8f	8f	8f
BLOWDOWN SIZE	KK	1.25	1.25	1.25	1.25	1.5	1.5	1.5
HIGH PRESSURE (150 PSI) BOILERS:								
STEAM OUTLET SIZE (NOTE 3)	N	3 NPT	3 NPT	3 NPT	3 NPT	3 NPT	4F	4F
BLOWDOWN SIZE	KK	1.25	1.25	1.25	1.25	1.25	1.25	1.25
GAS CONNECTIONS:								
VERTICAL LOCATION (NOTE 10)	Q	36	36	36	39	39	42	42
HORIZONTAL LOCATION (NOTE 4)	R	20	20	22	24	24	28	28
PILOT BURNER VALVE IPS	S	0.75	0.75	0.75	0.75	0.75	0.75	0.75
FLUE CONNECTIONS:								
FLUE SIZE (NOTES 6 & 9)	O	10	10	10	12	12	14	14
FLUE LOCATION	T	6.5	6.5	6.5	6.5	6.5	4.75	4.75
FLUE HEIGHT	TT	49	49	49	55	55	61	61
INSTALLATION CLEARANCES:								
COMBUSTION ASSEMBLY SWING	U	39	39	40	46	46	53	53
RELIEF DOOR SWING (NOTE 7)	V	21.5	21.5	21.5	25.5	25.5	29.5	29.5
TUBE REMOVAL, FRONT (NOTE 8)	XX	73	73	73	73	73	66	66
TUBE REMOVAL, REAR (NOTE 8)	X	71	71	71	71	71	72	72
RELIEF DOOR ASSEMBLY	VV	11	11	11	12	12	13	13
FLUE OUTLET PROJECTION	Y						2.25	2.25
BLOWER MOTOR:								
BLOWER HORSEPOWER		3	5	5	5	5	7.5	7.5
LOW NO _x BLOWER		3	5	7.5	7.5	7.5	7.5	10

See Notes on Page 8.

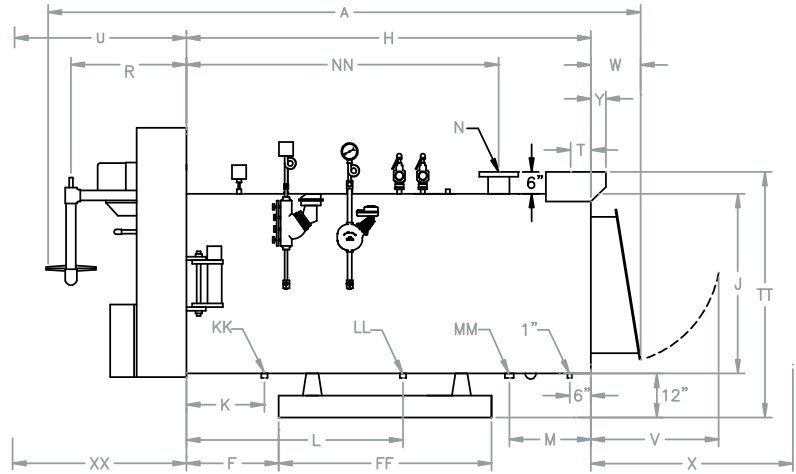
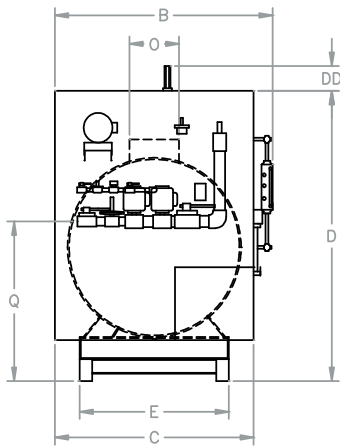

STEAM BOILER DIMENSIONS

HORSEPOWER		150	175	200	250	300	350	400	500	600	700	800	900
OVERALL DIMENSIONS:													
LENGTH	A	167	167	168	194	197	211	214	215	218	220	228	228
WIDTH	B	61	61	67	67	75	77	83	90	96	102	108	114
BURNER WIDTH	C	56	56	62	62	72	76	82	90	96	102	108	108
BURNER HEIGHT	D	79	79	87	87	90	102	107	111	116	124	129	131
SECONDARY AIR CAP HEIGHT	DD												N/A
BASE:													
WIDTH	E	42	42	48	48	54	54	57	63	66	72	78	84
LOCATION	F	26	26	26	3	3	3	3	3	3	3	3	3
LENGTH	FF	60	60	60	104	104	104	104	104	104	104	104	104
SHELL:													
LENGTH	H	114	114	114	140	140	140	140	140	140	140	140	140
DIAMETER INSIDE	J	48	48	54	54	60	60	66	72	78	84	90	96
SHELL CONNECTIONS:													
BLOWDOWN LOCATION	K	22	22	22	34	34	34	34	34	34	34	34	34
MANUAL FILL SIZE	LL	2	1.5	1.5	1.5	2	2	2	2	2.5	2.5	2.5	2.5
MANUAL FILL LOCATION	L	61	61	61	82	82	82	82	82	82	82	82	82
FEEDWATER INLET SIZE	MM	1.5	1.5	1.5	1.5	2	2	2	2	2.5	2.5	2.5	2.5
FEEDWATER INLET LOCATION	M	23	23	23	28	28	28	28	28	28	28	28	28
STEAM OUTLET LOCATION	NN	88	88	88	111	111	111	111	111	111	111	111	111
LOW PRESSURE (15 PSI) BOILERS:													
STEAM OUTLET SIZE (NOTE 3)	N	8f	10f	10f	10f	12f	12f	12f	12f	12f	12f	14f	14f
BLOWDOWN SIZE	KK	1.5	2	2	2	2	2	2	2	2	2	2	2
HIGH PRESSURE (150 PSI) BOILERS:													
STEAM OUTLET SIZE (NOTE 3)	N	4F	6F	6F	6F	6F	8F	8F	8F	8F	8F	10F	10F
BLOWDOWN SIZE	KK	1.25	1.25	1.5	1.5	1.5	1.5	1.5	1.5	2	2	2	2
GAS CONNECTIONS:													
VERTICAL LOCATION (NOTE 10)	Q	48	48	48	48	48	48	48	48	48	48	48	54
HORIZONTAL LOCATION (NOTE 4)	R	32	32	32	34	34	48	50	50	50	50	56	56
PILOT BURNER VALVE IPS	S	0.75	0.75	0.75	0.75	1	1	1	1	1.25	1.25	1.25	1.25
FLUE CONNECTIONS:													
FLUE SIZE (NOTES 6 & 9)	O	16	16	18	18	20	20	20	24	24	28	28	32
FLUE LOCATION	T	3.75	2.75	2.75	5.75	4.5	3.5	2.5	1.5	-0.5	-1.5	-2.5	7
FLUE HEIGHT	TT	67	67	73	73	79	79	85	91	97	103	109	116
INSTALLATION CLEARANCES:													
COMBUSTION ASSEMBLY SWING	U	62	62	67	67	74	88	90	96	101	106	114	126
RELIEF DOOR SWING (NOTE 7)	V	35.5	35.5	40	40	43	43	46	50	48	50	52	60
TUBE REMOVAL, FRONT (NOTE 8)	XX	66	66	66	88	88	88	88	88	88	88	88	88
TUBE REMOVAL, REAR (NOTE 8)	X	72	72	72	90	90	90	90	90	90	90	90	82
RELIEF DOOR ASSEMBLY	VV	14	14	15	15	16	16	17	18	17	18	18	20
FLUE OUTLET PROJECTION	Y	4.25	6.25	6.25	4.25	8.5	10.5	12.5	14.5	18.5	20.5	22.5	22.5
BLOWER MOTOR:													
BLOWER HORSEPOWER		7.5	7.5	10	15	15	20	20	25	25	30	30	40
LOW NO _x BLOWER		10	10	15	20	20	20	20	25	30	30	30	40

See Notes on Page 8.

NOTES

- Dimensions are accurate for layout but are subject to change. Certified prints are available upon request.
- Lifting lugs and insulation are not shown on drawing. The manhole, when furnished, is not shown.
- Openings are threaded unless indicated:
f = Class 150 ASA flange. F = Class 300 ASA flange.
Threaded couplings project 2" or less.
- Provide "R + 12" clearance from the right side of burner box to the right side wall to open hinged burner.
- Gas train may change with gas type and pressure.
- Outside diameter and dimensions are shown. (see note 10)
- Provide "J + 7" clearance from the rear end of the shell to swing the hinged back plate on 200 HP and larger boilers.
- Tubes may be removed from the front or rear.
- Dip tube (2" min.) provided on hot water outlet.
- Flue outlet dimension on 400 HP and larger boilers are inside diameter with angle iron flanged connection.
- Horizontal gas train dimension will vary based on required gas train components and addition of Low NO_x option. Gas train may extend beyond burner manifold dimension C.

MODEL NUMBER DESIGNATIONS

	PRESSURE	15 PSI	150 - 300 PSI
SIZE			
40-100 HP		MODEL 15C	MODEL 77C
125-900 HP		MODEL 15SR	MODEL 105E

STANDARD EQUIPMENT FURNISHED

Pressure Vessel: 15 PSI ASME stamped with "H" cloverleaf. 150 PSI ASME stamped with "S" cloverleaf.

Manholes: Standard on 400 HP or larger low pressure boilers and 200 Hp and larger high pressure boilers.

Handholes: Five (5) furnished, 3-1/2" x 4-1/2".

Energy X-tractors: High temperature stainless steel to provide high efficiency. Installed in each tube.

Insulation: 2" fiberglass with double painted steel jacket.

Relief Door: Gravity operated for rear access and safety.

Burner Assembly: Hinged to shell including:

- Fully modulating burner with parallel positioning controls.
- Individual burner nozzles.
- Air proving switch.
- Ignition transformer, spark and flame rods.
- Gas control trains with dual main shutoff cocks, pilot and main gas pressure regulators, gas volume adjustment and other components as follows:

Operating Pressure Control: Controls temperature.

High Limit Pressure Control: Manual reset limit control.

UL Labeled: Packaged boiler.

Low Water Cutoffs: MM157 with pump control switch. MM150-M secondary with manual reset.

Pressure Gauge: 4-1/2" dial type mounted on pigtail.

Lifting lugs: One or more provided on each boiler.

Base: Heavy duty structural steel skid.

Relief Valve(s): ASME rated for full boiler nozzle output at design pressure rating.

Flame observation ports: Two or more provided in combustion chamber to view burners.

Control Panel: With motor starter, control transformer with primary and secondary fuses & indicating lights. Siemens LMV5 Microprocessor based burner management system with real time MODBUS communication.

OPTIONAL AGENCY APPROVALS

- Factory Mutual
- CSD-1
- NFPA-85